

AVID PAGE Modeler 1.0 Beta

Release Notes

Introduction

This document describes the AVID PAGE (Parametric Aircraft Geometry Engine) Modeler used with a single component type (flying wing) including a list of features, introducing the user interface, and explaining the flying wing component parameters.

Features

- Adding and editing flying wing components
- Viewing flying wing components
- Loading and saving flying wing components
- Saving flying wing components as cross-section files or IGES files

User interface

The main window has a menu bar, a display window and a graphics toolbox. The three main menus are File, View and Edit. The menu items and their functions are listed below.

File		
	Open	Open a *.pag file
	Save	Save the current components to a *.pag file
	Save as Cross-section file	Save the current cross-section surface to a cross-section file
	Save as IGES file	Save the current components to an *.igs file
View		
	Single	Single view
	Side by side	Side by side view
	Multiple	Four views
Edit		
	Edit Component	Pop up the edit component dialog box

The edit component dialog box has three tabs: General Parameters including the component location, orientation and color, Shape Parameters, and Cross-Section Parameters including the number of points per cross-section and the number of cross-sections.

To change the view, Ctrl + mouse right click on the graph. A pop up menu will display. Select Isometric, Top, Side or Front.

Features that are not enabled in the standalone PAGE Modeler Version 1.0 Beta include:

1. In Graphics tool box:
 - a. Set viewing option button

2. In Edit Geometric Modeler Components Dialog Box:
 - a. From library combo box
 - b. Import PAGE button
 - c. Add to library button

Flying wing component parameters

1. Span
2. Leading Edge Sweep
3. Length (root chord)
4. Engine Length (engine face to nozzle)
5. Engine Location (tip of nose to engine face)
6. Engine Diameter
7. Engine Offset (engine center offset from WL reference plane)
8. Engine Cover Offset (aircraft surface offset above engine top)
9. Angle θ (theta 1, aircraft edge angle measured perpendicular to center line)
10. Front angle
11. Rear angle
12. Upper surface arc angle (alpha1)
13. Bottom surface angle θ (theta2)
14. Bottom surface arc angle (alpha2)

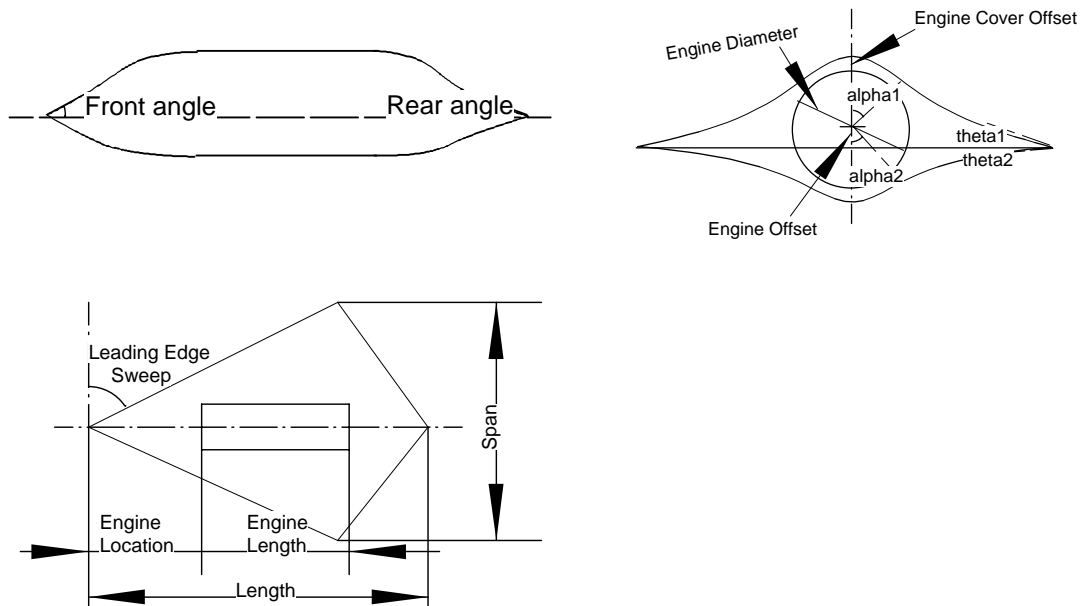

Figure 1: Component parameters

Some constraints on the parameters:

- The quadrilateral boundary is always convex; in Figure 2 solid lines have been trimmed to dashed lines.

*If $Span/2.0 * \tan(LeadingEdgeSweep) > Length$,
force $Span = Length / \tan(LeadingEdgeSweep)$*

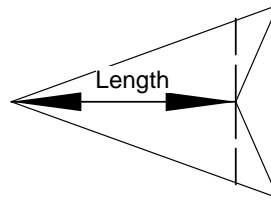

Figure 2: Quadrilateral boundaries

- The engine diameter plus the engine cover offset cannot be greater than the span.
*If $EngineDiameter + 2 * EngineCoverOffset > Span$,
force to use $Span$ as $EngineDiameter + 2 * EngineCoverOffset$.*
- The intersection of two tangent lines of the Bezier curve is always below the straight line connecting the two end points.
If the intersection D is above the straight line connecting the two end points B and C , D will be forced to be coincident with B and the curve is a straight line.

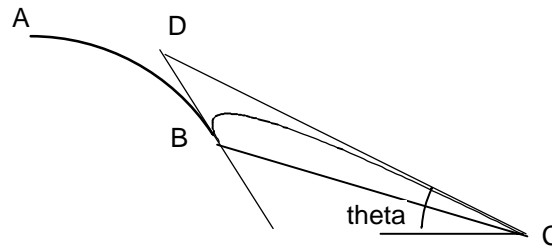

Figure 3: Unwanted Bezier curve shape

For support, e-mail support@avidllc.biz or call 540.961.0067

Released for Linux RedHat 7.2 (with Mesa OpenGL libraries), Mac OS 10.3.2, and Windows 2000/XP.
